

MLX90393 Triaxis[®] Magnetic Node

Datasheet

1. Features and Benefits

- Absolute Position Sensor IC featuring Triaxis[®] Hall Technology
- Simple & Robust Magnetic Design
- Miniature size for tiny assemblies
- Selectable SPI and I²C bus protocols
- Wide dynamic range (5-50mT) with on-the-fly programmable gain
- 2.2V-3.6V supply for battery powered applications, down to 1.8V IO voltage
- On board filter settings
- On the fly programmable operating modes and sleep times for micro-power use
- External and internal acquisition triggering modes
- External interrupt pin enables waking a microcontroller when the field changes
- On board temperature sensor

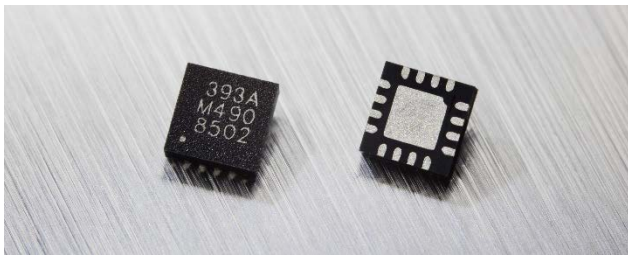

2. Application Examples

- Non-contacting HMI applications with push-pull functionality
 - Rotary knobs & dials
 - (Long stroke) Linear motion in one or two axes for levers & sliding switches
 - Joystick (gimball or ball & socket)
- Home Security 3D closure detection
- Accurate liquid level sensing
- Factory automation position sensing
- Magnetic fingerprint detection

3. Description

The MLX90393 brings the highest flexibility in the Triaxis portfolio's smallest packaged assembly. Additionally, the MLX90393 is designed for micropower applications, with programmable duty cycles in the range of 0.1% to 100% allowing for configurable power consumption based on system requirements.

The MLX90393 magnetic field sensor can be reprogrammed to different modes and with different settings at run-time to fine-tune the performance and power consumed. The sensor offers a 16-bit output proportional to the magnetic flux density sensed along the X, Y, and Z axes using the Melexis proprietary Triaxis technology and offers a 16-bit temperature output signal. These digital values are available via I²C and SPI, where the MLX90393 is a slave on the bus. Multiple sensors can be connected to the same bus, by A₀ and A₁ hardwired connection (4x) but also through ordering codes with different SW address (4x).

By selecting which axes are to be measured, the raw data can be used as input for further post-processing, such as for joystick applications, rotary knobs, and more complex 3D position sensing applications. Unparalleled performance is achieved with this sensor, which is primarily targeting industrial and consumer applications.

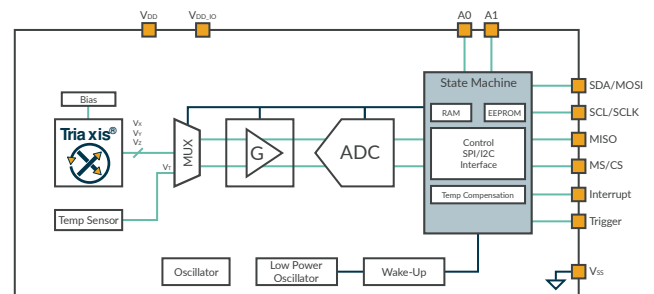

Figure 1: General Block Diagram

Contents

1. Features and Benefits.....	1
2. Application Examples.....	1
3. Description	1
4. Ordering Information	4
5. Functional Diagram	5
6. Glossary of Terms	5
7. Pinout	6
8. Absolute Maximum Ratings.....	7
9. General Electrical Specifications.....	8
10. Thermal Specification	9
11. Timing Specification	10
12. Magnetic Specification	11
13. Mode Selection.....	13
13.1. Burst mode.....	15
13.2. Single Measurement mode	16
13.3. Wake-Up on Change mode.....	16
14. Digital Specification	16
14.1. Command List	17
14.2. Status Byte	19
14.3. SPI Communication.....	19
14.4. I ² C Communication	21
14.4.1. I ² C Address	21
14.4.2. I ² C Principle	21
15. Memory Map.....	24
15.1. Parameter Description.....	25
15.1.1. ANA_RESERVED_LOW.....	26
15.1.2. BIST.....	26
15.1.3. Z_Series	26
15.1.4. GAIN_SEL[2:0]	27
15.1.5. HALLCONF[3:0].....	28
15.1.6. TRIG_INT_SEL.....	28

15.1.7. COMM_MODE[1:0].....	28
15.1.8. WOC_DIFF	28
15.1.9. EXT_TRIG	29
15.1.10. TCMP_EN	29
15.1.11. BURST_SEL[3:0].....	29
15.1.12. OSR2[1:0]	29
15.1.13. RES_XYZ[5:0]	29
15.1.14. DIG_FILT[1:0]	29
15.1.15. OSR[1:0]	29
15.1.16. SENS_TC_HT[7:0]	29
15.1.17. SENS_TC_LT[7:0].....	30
15.1.18. OFFSET_i[15:0].....	30
15.1.19. WO_i_THRESHOLDS[15:0].....	30
16. Recommended Application Diagram.....	31
1.1 I ² C	31
1.2 SPI.....	31
17. Packaging Specification	32
17.1. QFN package	32
18. Standard Information	32
19. ESD Precautions.....	33
20. Revision History	33
21. Contact	33
22. Disclaimer	34

4. Ordering Information

Product	Temperature	Package	Option Code	Packing Form	Definition
MLX90393	S (-20°C to 85°C)	LW	ABA-011	RE	I ² C address = 00011xx
MLX90393	S (-20°C to 85°C)	LW	ABA-012	RE	I ² C address = 00100xx
MLX90393	S (-20°C to 85°C)	LW	ABA-013	RE	I ² C address = 00101xx
MLX90393	S (-20°C to 85°C)	LW	ABA-014	RE	I ² C address = 00110xx
MLX90393	E (-40°C to 85°C)	LW	ABA-011	RE	I ² C address = 00011xx
MLX90393	E (-40°C to 85°C)	LW	ABA-012	RE	I ² C address = 00100xx
MLX90393	E (-40°C to 85°C)	LW	ABA-013	RE	I ² C address = 00101xx
MLX90393	E (-40°C to 85°C)	LW	ABA-014	RE	I ² C address = 00110xx

Table 1: Product Ordering Codes

Legend:

Temperature Code:	S: from -20°C to 85°C E: from -40°C to 85°C
Package Code:	“LW” for QFN-16 3x3x1mm package with wettable flanks
Option Code:	ABA-011: ABA-012: ABA-013: ABA-014: Different I ² C addresses – 5 most significant bits. The 2 least significant bits of the address are defined by the external address pins A ₀ and A ₁ .
Packing Form:	“RE for Reel”
Ordering Example:	“MLX90393-ELW-ABA-011-RE” MLX90393 Micropower magnetometer with I ² C address 00011xx where the last two bits are defined by external address pins A ₀ and A ₁ . In QFN package, temperature range -40°C to 85°C.

Table 2: Product Ordering Code Example

5. Functional Diagram

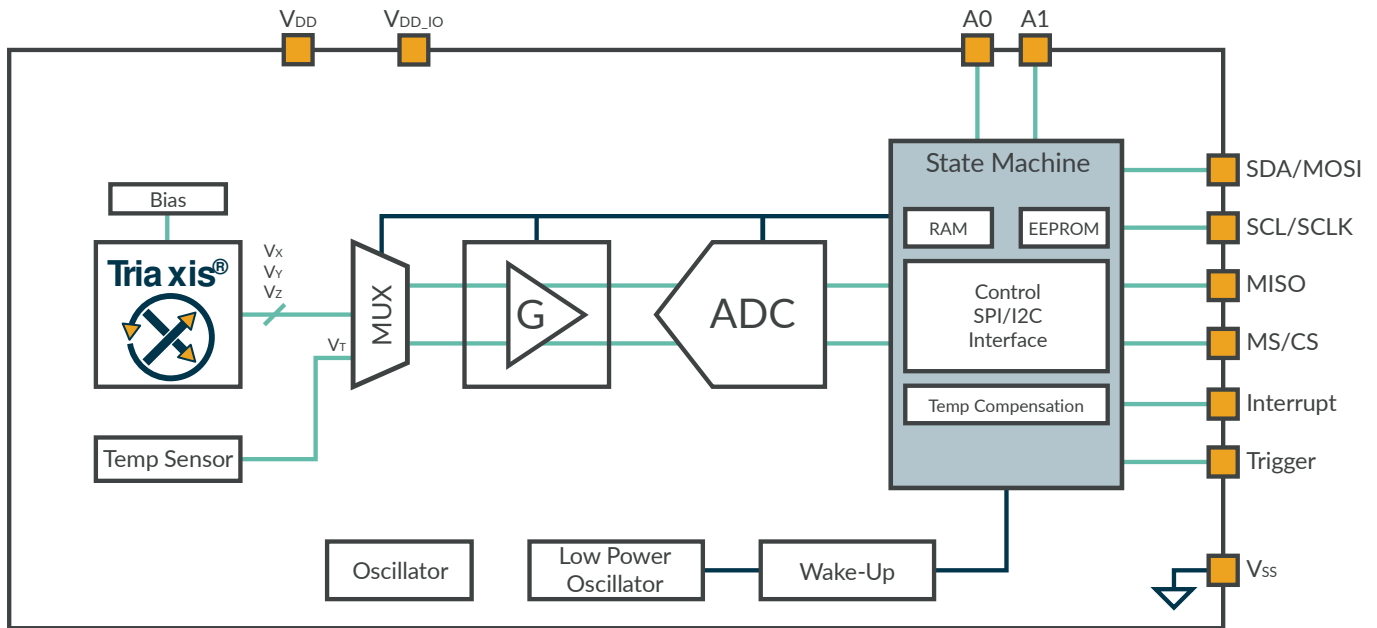

6. Glossary of Terms

Term	Definition
TC	Temperature Coefficient (in ppm/Deg.C.)
Gauss (G), Tesla (T)	Units for the magnetic flux density – 1 mT = 10 G
NC	Not Connected
PWM	Pulse Width Modulation
%DC	Duty Cycle of the output signal i.e. $T_{ON} / (T_{ON} + T_{OFF})$
ADC	Analog-to-Digital Converter
DAC	Digital-to-Analog Converter
LSb	Least Significant Bit
MSb	Most Significant Bit
DNL	Differential Non-Linearity
INL	Integral Non-Linearity
EMC	Electro-Magnetic Compatibility

7. Pinout

Pin #	Name	Type		Supply System	Wiring Recommendation		
		Primary	Secondary	Reference To	I ² C	4-wire SPI	3-wire SPI
1	INT	I/O out	N/A	VDD_IO	Optional	Optional	Optional
2	SENB/CS	I/O in	MLX Test	VDD_IO	To VDD_IO	Required	Required
3	SCL/SCLK	I/O in	MLX Test	VDD_IO	Required	Required	Required
4	N/C	--	--	--	--	--	--
5	SDA/MOSI	I/O bi	MLX Test	VDD_IO	Required	Required	Short together
6	MISO	I/O out	MLX Test	VDD_IO	Floating	Required	
7	INT/TRIG	I/O bi	N/A	VDD_IO	Optional	Optional	Optional
8	VDD_IO	Supply	N/A		Required	Required	Required
9	N/C	--	--	--	--	--	--
10	N/C	--	--	--	--	--	--
11	A1	I ² C Address LSB	MLX Test	VDD	To VDD/GND	To GND	To GND
12	A0	I ² C Address LSB	MLX Test	VDD	To VDD/GND	To GND	To GND
13	VSS	Ground	N/A		Required	Required	Required
14	N/C	--	--	--	--	--	--
15	VDD	Supply	N/A		Required	Required	Required
16	N/C	--	--	--	--	--	--

Table 3: Pinout Description

It is recommended to connect the N/C pins (Not Connected) to Ground.

8. Absolute Maximum Ratings

Parameter	Symbol	Min.	Typ.	Max.	Unit
V_{DD_MAX}	Analog Supply Voltage Limits	-0.3		4	V
$V_{DD_IO_MAX}$	Digital IO Supply Limits	-0.3		$\min(4, V_{DD}+0.3)$	V
$T_{STORAGE}$	Storage (idle) temperature range	-50		125	°C
ESD_{HBM}	According to AEC-Q100-002	2.5			kV
ESD_{CDM}	According to AEC-Q100-011-B (QFN)	750			V

Table 4: Absolute Maximum Ratings

Exceeding the absolute maximum ratings may cause permanent damage. Exposure to absolute maximum-rated conditions for extended periods may affect device reliability.

9. General Electrical Specifications

Parameter	Remark	Min	Nom	Max	Unit
V _{DD}	Analog Supply Voltage	2.2	3	3.6	V
V _{DD_IO}	Digital IO Supply	1.65	1.8	V _{DD}	V
V _{POR_LH}	Power-on Reset threshold (rising edge)		1.42	1.55	V
V _{POR_HL}	Power-on Reset threshold (falling edge)	1	1.31		V
I _{DD,CONVXY}	Conversion Current XY-axis		2.29	3	mA
I _{DD,CONVZ}	Conversion Current Z-axis		2.96	4	mA
I _{DD,CONVT}	Conversion Current Temperature		1.60	2	mA
I _{DD,STBY}	Standby Current ⁽¹⁾		43	60	μA
I _{DD,IDLE}	Idle Current ⁽²⁾	1	2.4	5	μA
I _{DD,NOM}	Nominal Current (TXYZ, Datarate = 10Hz, OSR=OSR2=0, DIG_FILT=4)		100		μA

Table 5: General Electrical Specifications

¹ Standby current corresponds to the current consumed in the digital where only the low power oscillator is running. This standby current is present in burst mode, or whenever the IC is counting down to start a new conversion.

² Idle current corresponds to the current drawn by the IC in idle mode where all operating functions are disabled except communications.

10. Thermal Specification

The MLX90393 has an on-board temperature sensor which measures the temperature of the MLX90393 sensor. The temperature can be read out via the communication protocol in a digital format

Parameter	Symbol	Min.	Typ.	Max.	Unit
T _{RES}	Temperature sensor resolution		45.2		LSB/°C
T ₂₅	Temperature sensor output at 25°C		46244		LSB _{16u}
T _{LIN}	Temperature Linearity ⁽³⁾		+/-3		°C
T _{OPERATING}	Operating temperature range [S code]	-20	25	85	°C
	Operating temperature range [E code]	-40			

Table 6: Thermal Specifications

³ The linearity is defined as the best fit curve through the digital temperature outputs over the entire temperature range. It includes ADC non-linearity effects

11. Timing Specification

The specifications are applicable at 25 Deg. C unless specified otherwise and for the complete supply range.

Parameter	Remark	Min	Nom	Max	Unit
Main Oscillator & Derived Timings					
T _{STBY}	Time from IDLE to STBY	400	500	600	μs
T _{ACTIVE}	Time from STBY to ACTIVE	8			μs
T _{CONVM}	Single Magnetic axis conversion time ⁽⁴⁾ typical programming range	0.192		66.56	ms
		[(2+2 ^{DIG_FILT})*2 ^{OSR} *0.064]			
T _{CONVT}	Temperature conversion time typical programming range	0.192		1.54	ms
		[2 ^{OSR2} *0.192]			
T _{CONV_SMM}	Total conversion time in Single Measurement Mode ⁽⁴⁾	T _{STBY} + T _{ACTIVE} + m*T _{CONVM} + T _{CONVT}			ms
T _{CONV_BURSTWOC}	Total conversion time in BURST or WOC Mode ⁽⁴⁾	T _{ACTIVE} + m*T _{CONVM} + T _{CONVT}			ms
T _{OSC_TRIM}	Trimming accuracy	-5		+5	%
T _{OSC_THD}	Thermal drift (full temperature range)	-5		+5	%
Low-power Oscillator & Derived Timings					
T _{INTERVAL}	Time in between 2 conversions (Burst mode or Wake-Up on Change) ⁽⁵⁾	0		1260	ms
		BURST_DATA_RATE * 20			
T _{LPOSC_TRIM}	Trimming accuracy	-4		+4	%
T _{LPOSC_THD}	Thermal drift (full temperature range)	-5		+5	%
Startup					
T _{POR}	Power-on-reset completion time		0.6	1.5	ms
External Trigger					
T _{TRIG}	Trigger pulse width (active high)	0.01		250	us

Table 7: Timing Specifications

⁴ This conversion time is defined as the time to acquire a single axis of the magnetic flux density. When measuring multiple axes they are obtained through time multiplexing. The conversion time is programmable through parameters OSR and DIG_FILT for magnetic values and OSR2 for the temperature value. The conversion sequence is TXYZ, opposite of the ZYXT argument of the command set.

⁵ The time T_{INTERVAL} is defined as the time between the end of one set of measurements (any combination of TXYZ) and the start of the following same set of measurements in BURST and WOC mode. As a result of this, the maximum output data rate is not only a function of T_{INTERVAL} but equals 1/(T_{CONV_BURSTWOC} + T_{INTERVAL}).

12. Magnetic Specification

The specifications are applicable at 25 Deg. C unless otherwise specified and for the complete supply voltage range.

Parameter	Remark	Min	Nom	Max	Unit
N _{ADC}	ADC span		17.4		bits
N _{OUT}	Output span (taken from 19 by RES _{XYZ})		16		bits
B _{RANGE}	Output range (function of RES _{XYZ})		RANGE from Table 1Table 4 / SENS _{ii}		mT
B _{SAT}	Magnetic saturation onset	50			mT
OFFS	Deviation from expected 0mT output		0		LSB
OFFS _{THD}	Offset thermal drift, Delta from 25°C ⁽⁶⁾		< ±1000		LSB
SENS _{XX} , SENS _{YY}	Programming range of magnetic resolution (μT/LSB) or sensitivity (LSB/mT) ⁽⁷⁾ [modifying GAIN_SEL and RES _{XYZ}], cfr. Table 3	3.220		0.161	μT/LSB
		311		6211	LSB/mT
SENS _{ZZ}		5.872		0.294	μT/LSB
		170		3406	LSB/mT

⁶ The offset thermal drift is defined as the deviation at 0Gauss from the output with respect to the output at 25°C when sweeping the temperature. The highest gradient (μT/°C) typically occurs at 85°C. The spec value is based on characterization on limited sample size at GAIN_SEL=0x7 and RES_XYZ=0x00.

⁷ The total axis sensitivity is programmable to support different applications, but has no Automatic Gain control on-chip as do the other angular position sensors from Melexis. The highest gain corresponds to at least the minimum +/-4.8mT magnetic measurement range and the magnetic resolution defined by SENS_{ii}.

Parameter	Remark	Min	Nom	Max	Unit
SENS _{X_Y} , SENS _{Y_X}	Cross-axis sensitivity (X/Y-axis sensitivity to Y/X magnetic fields)		< ±1		%
SENS _{X_Z} , SENS _{Y_Z}	Cross-axis sensitivity (X/Y-axis sensitivity to Z magnetic field)		< ±1		%
SENS _{Z_X} , SENS _{Z_Y}	Cross-axis sensitivity (Z-axis sensitivity to X and Y magnetic fields)		< ±1		%
SENS _{THD}	Sensitivity thermal drift Delta from 25°C ⁽⁸⁾	-3		+3	%

Table 8: Magnetic Specifications

⁸ The sensitivity thermal drift is expressed as a band around the sensitivity at 25°C. It is applicable on wafer level trimming, but can be influenced by packaging (overmolding).

12.1. Noise vs Conversion Time

The MLX90393 provides configurable filters to adjust the tradeoff between current consumption, noise, and conversion time. See section 15.1.5 for details on selecting the conversion time by adjusting OSR and DIG_FILT.

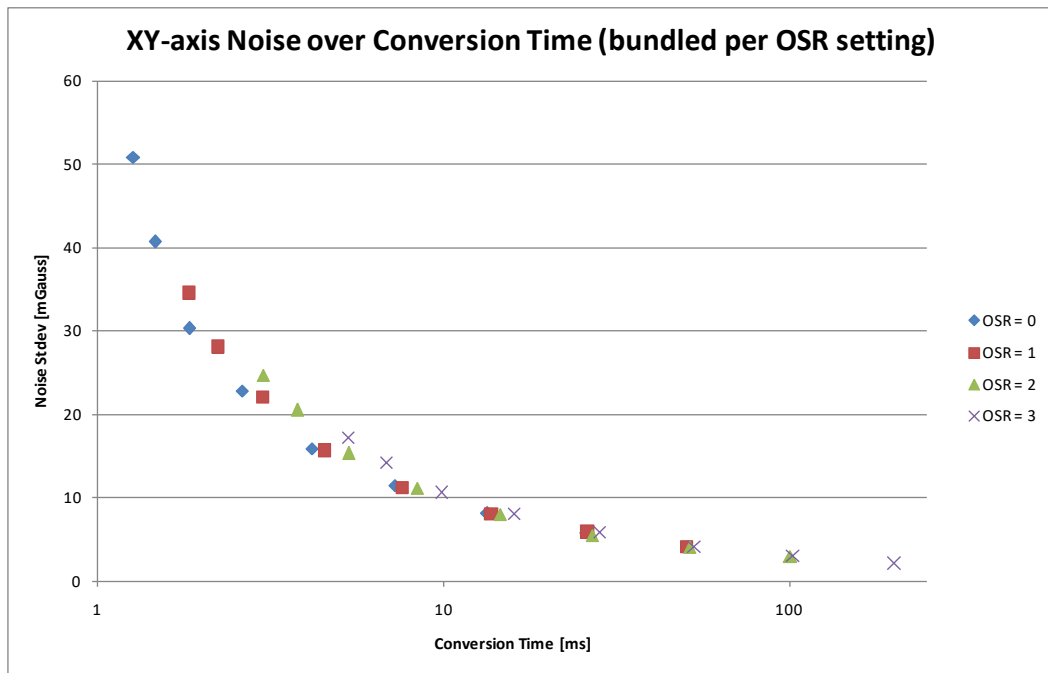

Figure 2: XY axis RMS noise versus conversion time, expressed in mGauss for GAIN_SEL = 0x7

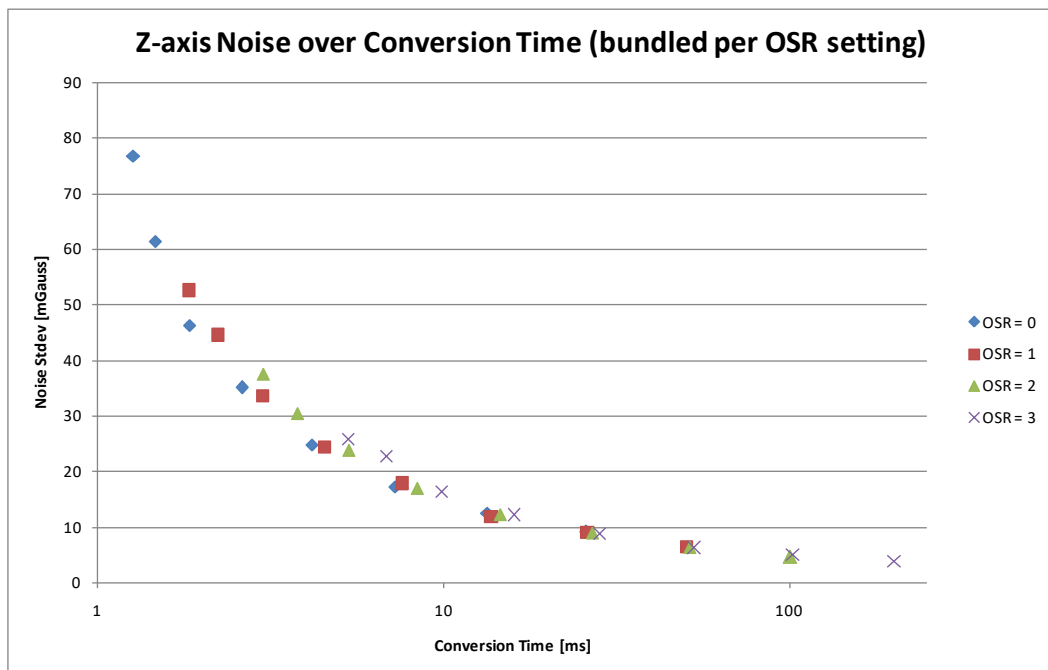

Figure 3: Z axis RMS noise versus conversion time, expressed in mGauss for GAIN_SEL = 0x7

13. Mode Selection

The MLX90393 can operate in three modes. They are: Burst mode, Single Measurement mode, and Wake-On-Change mode.

- Burst mode

The ASIC will have a programmable data rate at which it will operate. This data rate implies auto-wakeup and sequencing of the ASIC, flagging that data is ready on a dedicated pin (INT/DRDY). The maximum data rate corresponds to continuous burst mode, and is a function of the chosen measurement axes. For non-continuous burst modes, the time during which the ASIC has a counter running but is not doing an actual conversion is called the Standby mode (STBY).

- Single Measure mode

The master will ask for data via the corresponding protocol (I²C or SPI), waking up the ASIC to make a single conversion, immediately followed by an automatic return to sleep mode (IDLE) until the next polling of the master. This polling can also be done by strobing the TRG pin instead, which has the same effect as sending a protocol command for a single measurement.

- Wake-Up on Change

This mode is similar to the burst mode in the sense that the device will be auto-sequencing, with the difference that the measured component(s) is/are compared with a reference and in case the difference is bigger than a user-defined threshold, the DRDY signal is set on the designated pin. The user can select which axes and/or temperature fall under this cyclic check, and which thresholds are allowed.

The user can change the operating mode at all time through a specific command on the bus. The device waits in IDLE mode after power-up, but with a proper user command any mode can be set after power-up. Changing to Burst or WOC mode, coming from Single Measure mode, is always accompanied by a measurement first. The top-level state diagram indicating the different modes and some relevant timing is shown below in Figure 4. In the Measure state, the MDATA flag will define which components will be measured (ZYXT). The order of conversion is defined as TXYZ and can not be modified by the user, only the combination of axes is a degree of freedom.

Arrows indicated in grey are the direct result of an Exit command. The main difference between STANDBY and WOC_IDLE is that in STANDBY mode, all analog circuitry is ready to make a conversion, but this is accompanied by a larger current consumption than IDLE mode. For burst mode this extra current consumption is justified because the emphasis is more on accurate timing intervals, avoiding the delay of T_{STBY} before conversion and supporting an efficient continuous burst mode without standby overhead.

It is the user's responsibility to read back the measured data as the MLX90393 is a slave device on the bus. Even in burst mode and WOC mode when the MLX90393 is auto-sequencing, the master will be responsible for collecting the acquired sensor data.

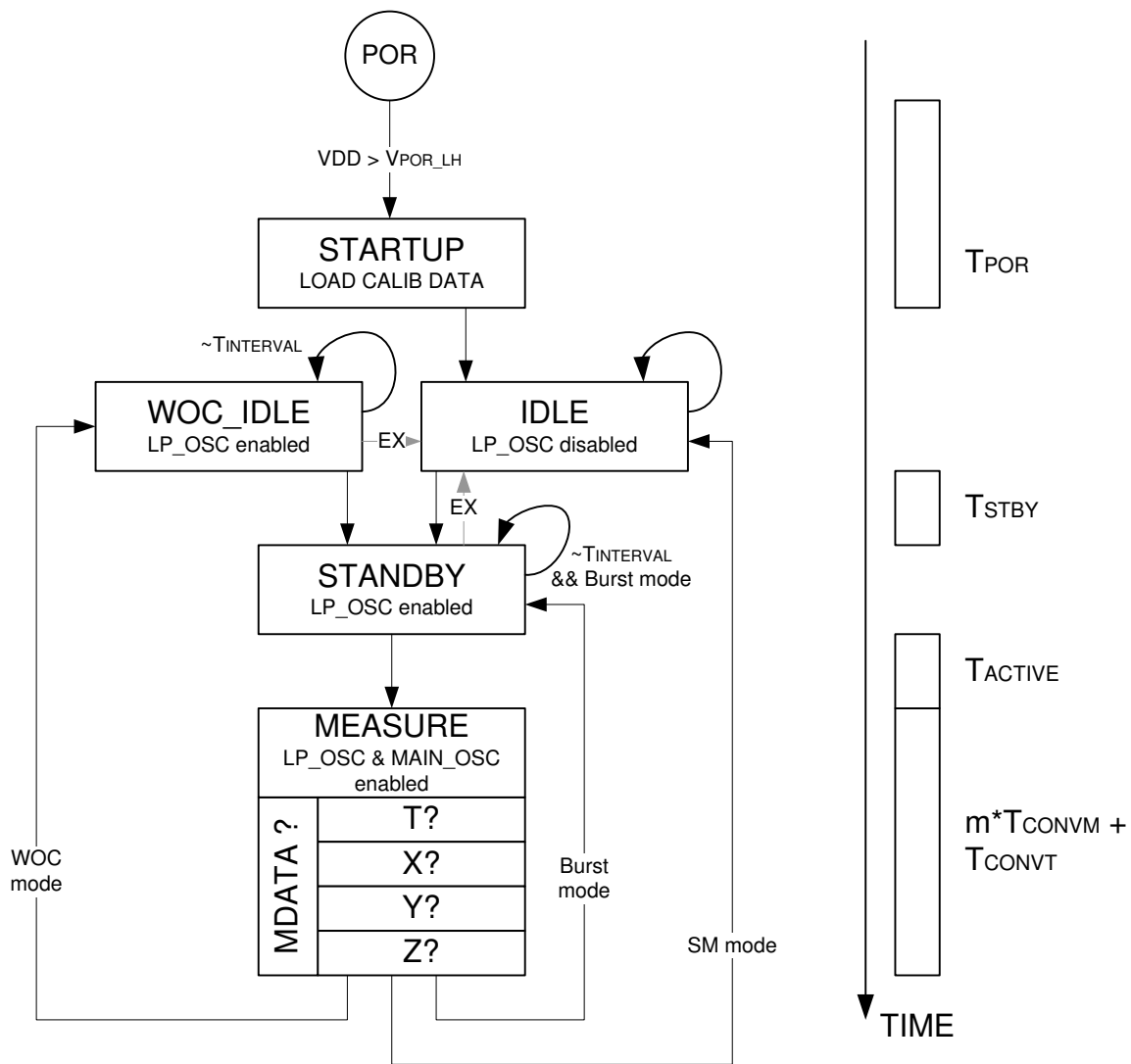

Figure 4: Top-level state diagram with indication of timings

13.1. Burst mode

When the sensor is operating in burst mode, it will make conversions at specific time intervals. The programmability of the user is the following:

- Burst speed ($T_{INTERVAL}$) through parameter BURST_DATA_RATE
- Conversion time (T_{CONV}) through parameters OSR, OSR2 and DIG_FILT
- Axes/Temperature (MDATA) through parameter BURST_SEL or via the command argument (ZYXT)

Whenever the MLX90393 has made the selected conversions (based on MDATA), the DRDY signal will be set (active H) on the INT and/or INT/TRG pin to indicate that the data is ready for readback. It will remain high until the master has sent the command to read out at least one of the converted quantities (ZYXT). Should the master have failed to read out any of them by the time the sensor has made a new conversion, the INT/DRDY pin will be strobed low for 10us, and the next rising edge will indicate a new set of data is ready.

13.2. Single Measurement mode

Whenever the sensor is set to this mode (or after startup) the MLX90393 goes to the IDLE state where it awaits a command from the master to perform a certain acquisition. The duration of the acquisition will be the concatenation of the T_{STBY} , T_{ACTIVE} , $m \cdot T_{CONVM}$ (with m # of axes) and T_{CONVT} . The conversion time will effectively be programmable by the user (see burst mode), but is equally a function of the required axes/temperature to be measured.

Upon reception of such a polling command from the master, the sensor will make the necessary acquisitions, and set the DRDY signal high to flag that the measurement has been performed and the master can read out the data on the bus at his convenience. The INT/DRDY will be cleared either when:

- The master has issued a command to read out at least one of the measured components
- The master issues an Exit (EX) command to cancel the measurement
- The chip is reset, after POR (Power-on reset) or Reset command (RT)

13.3. Wake-Up on Change mode

The Wake-Up on Change (WOC) functionality can be set by the master with as main purpose to only receive an interrupt when a certain threshold is crossed. The WOC mode will always compare a new burst value with a reference value to assess if the difference between both exceeds a user-defined threshold. The reference value is defined as one of the following:

- The first measurement of WOC mode is stored as reference value once, because of a measurement. This measurement at "t=0" is then the basis for comparison or,
- The reference for acquisition(t) is always acquisition(t-1), in such a way that the INT signal will only be set if the derivative of any component exceeds a threshold.

The in-application programmability is the same as for burst mode, but now the thresholds for setting the interrupt are also programmable by the user, as well as the reference, if the latter is data(t=0) or data(t-1).

14. Digital Specification

The supported protocols are I²C and SPI. The SENB/CS pin is used to define the protocol to be used:

- /CS = 0 for SPI, addressing the MLX90393 slave in SPI mode (3- and 4-wire), but releasing this line in between commands (no permanent addressing allowed)
- /CS = 1 for I²C, addressing the MLX90393 slave when the correct address is transmitted over the bus (permanently kept high)

To ensure the activity on the SPI bus cannot be accidentally interpreted as I²C protocol, programming bits are available in the memory of the MLX90393 to force the communication mode. It concerns the COMM_MODE[1:0] bits with the following effect:

COMM_MODE[1]	COMM_MODE[0]	Description
0	X	The mode in which the first valid command is transmitted to the MLX90393 defines the operating mode (SPI or I ² C) for all its future commands, until a reset (hard or soft) is done.
1	0	SPI mode only
1	1	I ² C mode only

Table 9: Communication mode definition

14.1. Command List

The MLX90393 only listens to a specific set of commands. Apart from the Reset command, all commands generate a status byte that can be read out. The table below indicates the 10 different commands that are (conditionally) accepted by the MLX90393. The MLX90393 will always acknowledge a command in I²C, even if the command is not a valid command. Interpreting the associated status byte is the method for verification of command acceptance.

Command Set						
Command Name	Symbol	#	CMD1 byte	CMD2 byte	CMD3 byte	CMD4 byte
Start Burst Mode	SB	1	0001 zyxt	N/A	N/A	N/A
Start Wake-up on Change Mode	SW	2	0010 zyxt	N/A	N/A	N/A
Start Single Measurement Mode	SM	3	0011 zyxt	N/A	N/A	N/A
Read Measurement	RM	4	0100 zyxt	N/A	N/A	N/A
Read Register	RR	5	0101 0abc	{A5...A0,0,0}	N/A	N/A
Write Register	WR	6	0110 0abc	D15...D8	D7...D0	{A5...A0,0,0}
Exit Mode	EX	8	1000 0000	N/A	N/A	N/A
Memory Recall	HR	D	1101 0000	N/A	N/A	N/A
Memory Store	HS	E	1110 0000	N/A	N/A	N/A
Reset	RT	F	1111 0000	N/A	N/A	N/A

Table 10: Command List

The argument for the volatile memory access commands (RR/WR) «abc» should be set to 0x0h, in order to get normal read-out and write of the memory.

The argument in all mode-starting commands (SB/SW/SM) is a nibble specifying the conversions to be performed by the sensor in the following order «zyxt». For example, if only Y axis and temperature are to be measured in Single Measurement mode the correct command to be transmitted is 0x35h. The sequence of measurement execution on-chip is inverted to «TXYZ», so T will be measured before X, followed by Y and finally Z. By issuing an all-zero «zyxt» nibble, the BURST_SEL value from RAM will be used instead of the empty argument of the command.

14.2. Status Byte

The status byte is the first byte transmitted by the MLX90393 in response to a command issued by the master. It is composed of a fixed combination of informative bits:

bit 7	bit 6	bit 5	bit 4	bit 3	bit 2	bit 1	bit 0
BURST_MODE	WOC_MODE	SM_MODE	ERROR	SED	RS	D1	D0

Table 11: Status Byte Definition

- **MODE bits**
 These bits define in which mode the MLX90393 is currently set. Whenever a mode transition command is rejected, the first status byte after this command will have the expected mode bit cleared, which serves as an indication that the command has been rejected, next to the ERROR bit. The SM_MODE flag can be the result of an SM command or from raising the TRG pin when TRG mode is enabled in the volatile memory of the MLX90393.
- **ERROR bit**
 This bit is set in case a command has been rejected or in case an uncorrectable error is detected in the memory, a so called ECC_ERROR. A single error in the memory can be corrected (see SED bit), two errors can be detected and will generate the ECC_ERROR. In such a case all commands but the RT (Reset) command will be rejected. The error bit is equally set when the master is reading back data while the DRDY flag is low.
- **SED bit**
 The single error detection bit simply flags that a bit error in the non-volatile memory has been corrected. It is purely informative and has no impact on the operation of the MLX90393.
- **RS bit**
 Whenever the MLX90393 gets out of a reset situation – both hard and soft reset – the RS flag is set to highlight this situation to the master in the first status byte that is read out. As soon as the first status byte is read, the flag is cleared until the next reset occurs.
- **D[1:0] bits**
 These bits only have a meaning after the RR and RM commands, when data is expected as a response from the MLX90393. The number of response bytes correspond to $2 * D[1:0] + 2$, so the expected byte counts are either 2, 4, 6 or 8. For commands where no response is expected, the content of D[1:0] should be ignored.

14.3. SPI Communication

The MLX90393 can handle SPI communication at a bitrate of 10Mhz. The SPI communication is implemented in a half-duplex way, showing high similarities with I²C communication, but addressing through the \CS (Chip Select) pin instead of through bus arbitration. The half-duplex nature is at the basis of the supported 3-wire SPI operation. SPI mode 3 is implemented: CPHA=1 (data changed on leading edge and captured on trailing edge, and CPOL=1 (high level is inactive state). The Chip Select line is active-low.

Symbol	Parameter	Value		Unit
		Min	Max	
$t_{c(SPC)}$	SPI clock cycle	100		ns
$f_{c(SPC)}$	SPI clock frequency		10	MHz
$t_{su(CS)}$	CS setup time	5		ns
$t_{h(CS)}$	CS hold time	10		
$t_{su(SI)}$	SDI input setup time	5		
$t_{h(SI)}$	SDI input hold time	15		
$t_{v(SO)}$	SDO valid output time		50	
$t_{h(SO)}$	SDO output hold time	5		
$t_{dis(SO)}$	SDO output disable time		50	

Figure 3. SPI slave timing diagram (2)

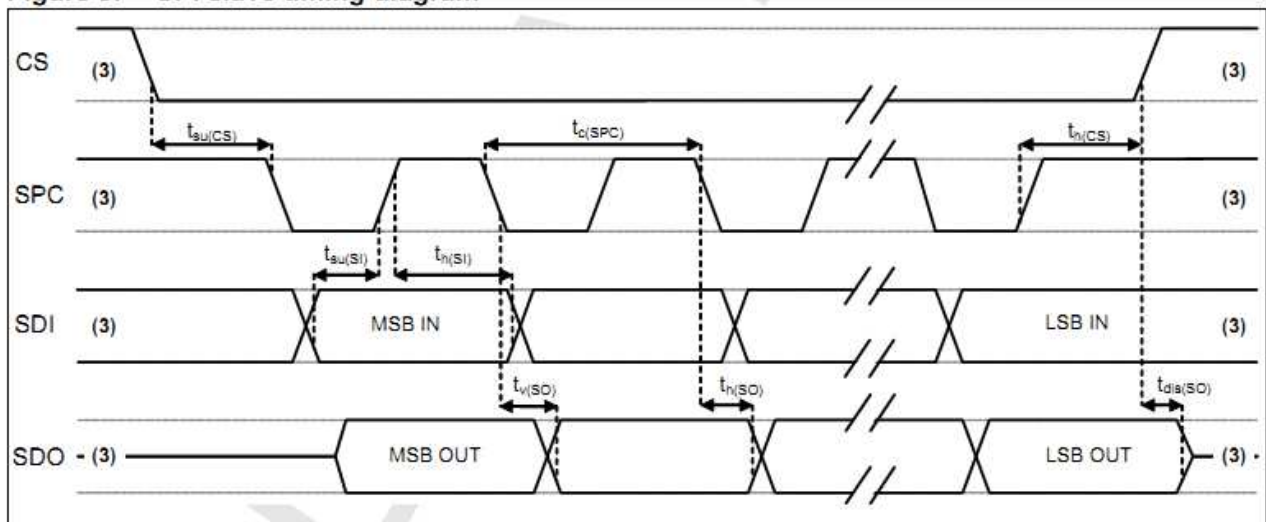

1. Values are guaranteed at 10 MHz clock frequency for SPI with both 4 and 3 wires, based on characterization results, not tested in production
2. Measurement points are done at $0.2 \cdot V_{dd_IO}$ and $0.8 \cdot V_{dd_IO}$, for both Input and output port

The communication is also bundled in bytes, equally MSB first and MSByte first. A command can of course consist of more than 1 byte (refer to Chapter 8.1) as can the response be from the MLX90393 in the form of multiple bytes after the status byte (not shown in Figure 5)

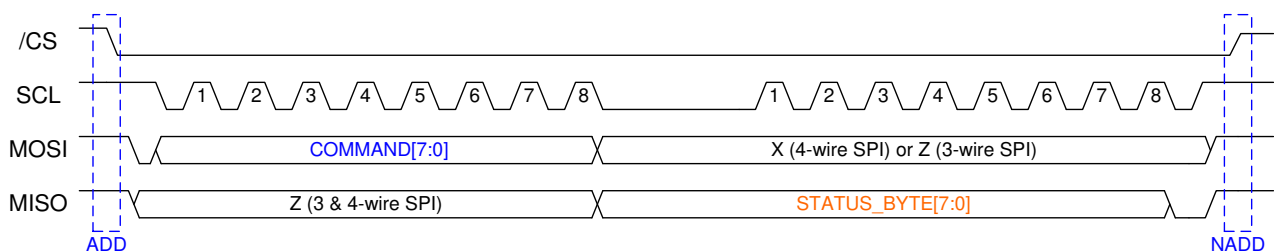

Figure 5: SPI communication example

14.4. I²C Communication

14.4.1. I²C Address

The I²C address is made up of some hard-coded bits and a memory written value as follows:

I2C_ADDR[6:0] = {EE_I2C_ADDR[4:0],A1,A0} with A_i the user-selectable active-high value of the input pads of the MLX90393, referred to the V_{DD} supply system and EE_I2C_ADDR[4:0] default programmed to 0x03h, but factory accessible for overwrite. Table 7 below indicated the available ordering codes for different EE_I2C_ADDR[4:0] factory calibrated values. This permits connection of up to 16 distinguishable sensors on the bus: 4 ordering codes x 4 possible hardwired A₁A₀ connections for each.

Ordering Code	EE_I2C_ADDR[4:0]	7-bit I ² C addresses possible
MLX90393xLW-ABA-011-RE	0x03h	0x0Ch, 0x0Dh, 0x0Eh, 0x0Fh
MLX90393xLW-ABA-012-RE	0x04h	0x10h, 0x11h, 0x12h, 0x13h
MLX90393xLW-ABA-013-RE	0x05h	0x14h, 0x15h, 0x16h, 0x17h
MLX90393xLW-ABA-014-RE	0x06h	0x18h, 0x19h, 0x1Ah, 0x1Bh

Table 12: I²C address ordering codes.

14.4.2. I²C Principle

The MLX90393 supports I²C communication in both Standard Mode and Fast Mode. Bytes are transmitted MSB first, and in order to reconstruct words, the bytes need to be concatenated MSByte first. The general principle of communication is always the same:

- Initiating the communication is always done by the Master (Start condition S)
- Addressing the Slave (MLX90393) followed by a cleared bit to indicate the Master intends to write something to the specific addressed Slave
- Acknowledging by the Slave if the transmitted address corresponds to the Slave's I²C address. If the latter isn't the case, any further activity on the bus except a Sr (Start Repeat) and P (Stop) condition will be ignored by the MLX90393
- Sending a Command Byte by the Master, as depicted in Figure 6. The Slave will always acknowledge this, even if it is an unrecognized command. A command such as WR and RR consist of more than 1 byte, which can then be transmitted sequentially over the I²C bus. Referring to Figure 6 the COMMAND byte should then be a sequence of COMMAND byte1, byte2, etc...
- Issuing a Start Repeat (Sr) condition by the Master in order to restart the addressing phase
- Addressing the Slave (MLX90393) followed by a set bit to indicate the Master intends to read something from the specific addressed Slave
- Acknowledging by the Slave if the transmitted address corresponds to the Slave's I²C address. If the latter isn't the case, any further activity on the bus except a Sr (Start Repeat) and P (Stop) condition will be ignored by the MLX90393

- Transmitting the Status Byte by the Slave, who is in control of the bus. Following the RR and RM commands the sensor returns additional data bytes after the status byte.
- Acknowledging by the Master if the data is well received
- Generating a Stop condition (P) by the master

The Master controlled bus activity is shown in blue, the Slave controlled bus activity is shown in orange. In case a command is longer than a single byte (see Table 6), the bytes are transmitted sequentially before generating the Start Repeat (Sr) condition.

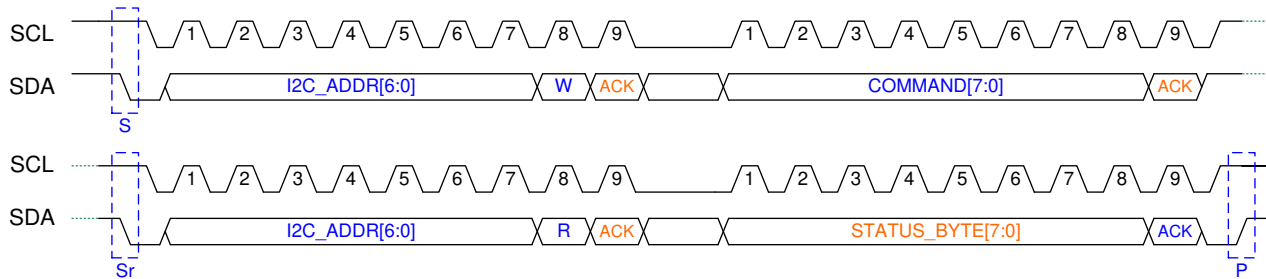
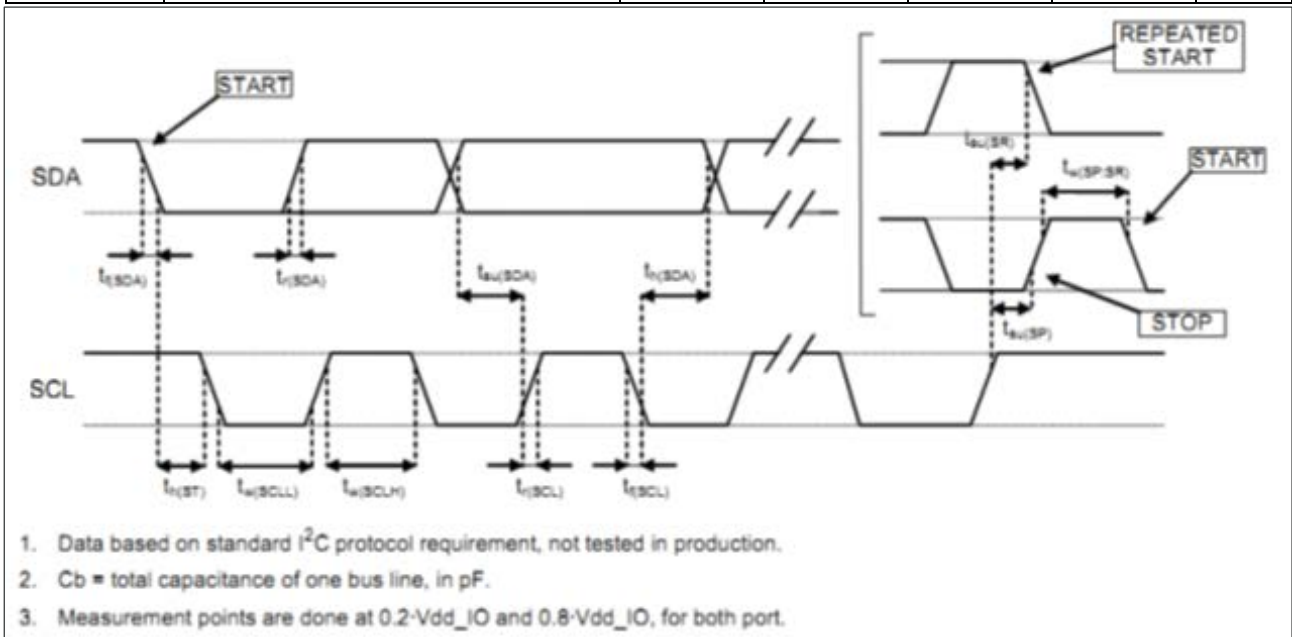

Figure 6: Default I²C communication example with status byte readback

The same applies to the Slave responses: following RR and RM commands, the Slave response is more than just the Status Byte. There as well, the data is partitioned in bytes that are transmitted sequentially by the slave. It is the Master’s responsibility to issue enough clocking pulses to read back all the data. Finding out how many bytes is possible by decoding the Status Byte information, see Section Status Byte.

Finally, the master is also free to not read back the status byte when issuing a command. In doing so, he loses the ability to see if the command was received properly by the MLX90393. Moreover, the first SM command issued by the master after power-up or reset should have the status byte read back to get valid measurement data back.

Symbol	Parameter	I ² C standard mode		I ² C fast mode		Unit
		Min	Max	Min	Max	
f _(SCL)	SCL clock frequency	0	100	0	400	kHz
t _{w(SCLL)}	SCL clock low time	4.7		1.3		
t _{w(SCLH)}	SCL clock high time	4.0		0.6		μs
t _{su(SDA)}	SDA setup time	250		100		ns
t _{h(SDA)}	SDA data hold time	0	3.45	0	0.9	μs
t _{r(SDA), t_{r(SCL)}}	SDA and SCL rise time		1000	20+0.1C _b	300	ns
t _{f(SDA), t_{f(SCL)}}	SDA and SCL fall time		300	20+0.1C _b	300	
t _{h(ST)}	START condition hold time	4		0.6		μs
t _{su(SR)}	Repeated START condition setup time	4.7		0.6		
t _{su(SP)}	STOP condition setup time	4		0.6		
t _{w(SP:SR)}	Bus free time between STOP and START condition	4.7		1.3		



15. Memory Map

The MLX90393 has 1kbit of non-volatile memory, and the same amount of volatile memory. Each memory consists out of 64 addresses containing 16 bit words. The non-volatile memory has automatic 2-bit error detection and 1-bit error correction capabilities per address. The handling of such corrections & detections is explained in Section Status Byte.

The memory is split in 2 areas:

- Customer area [address 0x00h to 0x1Fh]
- Melexis area [address 0x20h to 0x3Fh]

The RR and WR commands impact the volatile memory only, there no direct access possible to the non-volatile memory. The customer area of the volatile memory is bidirectionally accessible to the customer; the Melexis area is write-protected. Only modifications in the blue area are allowed with the WR command. The adjustments in the customer area can be stored in the permanent non-volatile memory with the STORE command HS, which copies the entire volatile memory including the Melexis area to the non-volatile one. With the HR command the non-volatile memory content can be recalled to the volatile memory, which can restore any modifications due to prior WR commands. The HR step is performed automatically at start-up of the ASIC, either through cold reset or warm reset with the RT command.

The above is graphically shown in Figure 7.

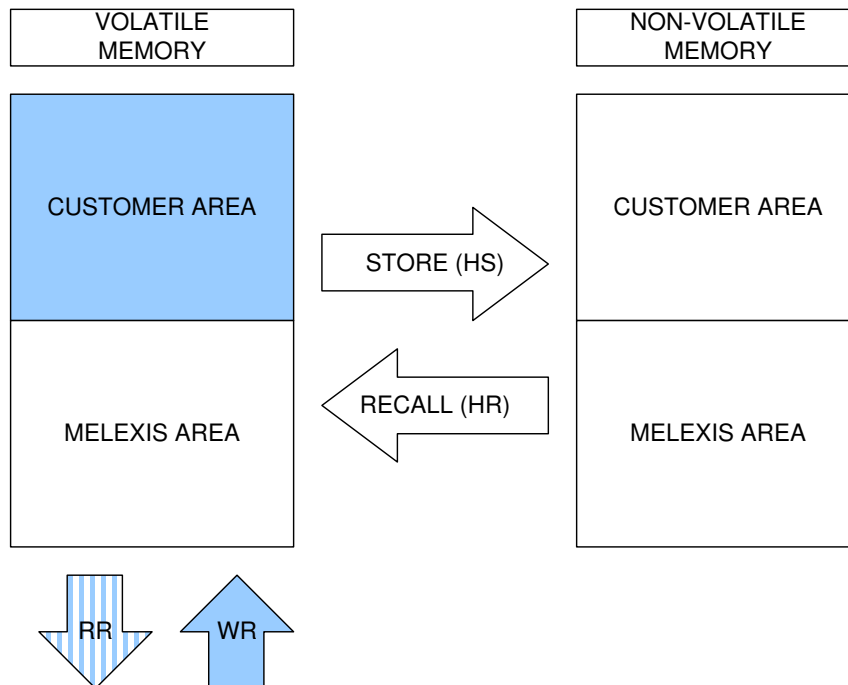

Figure 7: The memories of the MLX90393, their areas and the impacting commands.

The customer area houses 3 types of data:

- Analog configuration bits
- Digital configuration bits

- Informative (free) bits

The latter can be filled with customer content freely, and covers the address span from (and including) 0x0Ah to 0x1Fh, a total of 352 bits. The memory mapping of volatile and non-volatile memory on address level is identical. The volatile memory map is given in Figure 8.

ADDRESS	BIT NUMBER															
	15	14	13	12	11	10	9	8	7	6	5	4	3	2	1	0
0x00h	ANA_RESERVED_LOW							BIST	Z_SERIES	GAIN_SEL			HALLCONF			
0x01h	TRIG_INT	COMM_MODE	WOC_DIFF	EXT_TRIG	TCMP_EN	BURST_SEL (zyxt)			BURST_DATA_RATE							
0x02h	OSR2				RES_XYZ				DIG_FILT				OSR			
0x03h	SENS_TC_HT								SENS_TC_LT							
0x04h	OFFSET_X															
0x05h	OFFSET_Y															
0x06h	OFFSET_Z															
0x07h	WOXY_THRESHOLD															
0x08h	WOZ_THRESHOLD															
0x09h	WOT_THRESHOLD															
0x0Ah	FREE															
0x0Bh	FREE															
0x0Ch	FREE															
0x0Dh	FREE															
0x0Eh	FREE															
0x0Fh	FREE															
0x10h	FREE															
0x11h	FREE															
0x12h	FREE															
0x13h	FREE															
0x14h	FREE															
0x15h	FREE															
0x16h	FREE															
0x17h	FREE															
0x18h	FREE															
0x19h	FREE															
0x1Ah	FREE															
0x1Bh	FREE															
0x1Ch	FREE															
0x1Dh	FREE															
0x1Eh	FREE															
0x1Fh	FREE															

Figure 8: Customer area memory map.

The non-volatile memory can only be written (HS store command) if pin VDD is supplied with 3.3V minimum, otherwise the write sequence cannot be performed in a reliable way. Additionally, this HS command was designed to be used as one-time calibration, but not as multi write-cycle memory within the application. In case memory is written within the application, the number of write cycles should be kept to a minimum. There is no limit to the write cycles in the volatile memory (WR write command).

15.1. Parameter Description

The meaning of each customer accessible parameter is explained in this section. The customer area of both the volatile and the non-volatile memory can be written through standard SPI and I²C communication, within the application. No external high-voltages are needed to perform such operations, nor access to dedicated pins that need to be grounded in the application.

Parameter	Description
ANA_RESERVED_LOW	Reserved IO trimming bits
BIST	Enabled the on-chip coil, applying a Z-field [Built-In Self Test]
Z_SERIES	Enable all plates for Z-measurement
GAIN_SEL[2:0]	Analog chain gain setting, factor 5 between min and max code
HALLCONF[3:0]	Hall plate spinning rate adjustment

Parameter	Description
TRIG_INT_SEL	Puts TRIG_INT pin in TRIG mode when cleared, INT mode otherwise
COMM_MODE[1:0]	Allow only SPI [10b], only I ² C [11b] or both [0Xb] according to CS pin
WOC_DIFF	Sets the Wake-up On Change based on $\Delta\{\text{sample}(t), \text{sample}(t-1)\}$
EXT_TRIG	Allows external trigger inputs when set, if TRIG_INT_SEL = 0
TCMP_EN	Enables on-chip sensitivity drift compensation
BURST_SEL[3:0]	Defines the MDATA in burst mode if SB command argument = 0
BURST_DATARATE[6:0]	Defines T _{INTERVAL} as BURST_DATA_RATE * 20ms
OSR2[1:0]	Temperature sensor ADC oversampling ratio
RES_XYZ[5:0]	Selects the desired 16-bit output value from the 19-bit ADC
DIG_FILT[1:0]	Digital filter applicable to ADC
OSR[1:0]	Magnetic sensor ADC oversampling ratio
SENS_TC_HT[7:0]	Sensitivity drift compensation factor for T < T _{REF}
SENS_TC_LT[7:0]	Sensitivity drift compensation factor for T > T _{REF}
OFFSET_i[15:0]	Constant offset correction, independent for i = X, Y, Z
WOi_THRESHOLD[15:0]	Wake-up On Change threshold, independent for i = X, Y, Z and T

Table 13: NVRAM parameter description

15.1.1. ANA_RESERVED_LOW

Reserved bits for analog trimming at Melexis factory. Do not modify.

15.1.2. BIST

Enables (1) or disables (0) the built in self-test coil. In normal operation set to 0.

15.1.3. Z_Series

Enables series connection of hall plates for Z axis measurement. In normal operation set to 0.

15.1.4. GAIN_SEL[2:0]

Sets the analog gain to the desired value. The sensitivity is dependent on the axis (X and Y have higher sensitivity) as well as the setting of the RES_XYZ[5:0] parameter. The relationship is given in the below table.

Table for HALLCONF = 0xC, sensitivity in $\mu\text{T}/\text{LSB}$:

GAIN_SEL	RES = 0		RES = 1		RES = 2		RES = 3	
	SENS _{XY}	SENS _Z	SENS _{XY}	SENS _Z	SENS _{XY}	SENS _Z	SENS _{XY}	SENS _Z
0	0.751	1.210	1.502	2.420	3.004	4.840	6.009	9.680
1	0.601	0.968	1.202	1.936	2.403	3.872	4.840	7.744
2	0.451	0.726	0.901	1.452	1.803	2.904	3.605	5.808
3	0.376	0.605	0.751	1.210	1.502	2.420	3.004	4.840
4	0.300	0.484	0.601	0.968	1.202	1.936	2.403	3.872
5	0.250	0.403	0.501	0.807	1.001	1.613	2.003	3.227
6	0.200	0.323	0.401	0.645	0.801	1.291	1.602	2.581
7	0.150	0.242	0.300	0.484	0.601	0.968	1.202	1.936

Table 14: Sensitivity table for given gain and resolution selection for HALLCONF=0xC

Table for HALLCONF = 0x0, sensitivity in $\mu\text{T}/\text{LSB}$:

GAIN_SEL	RES = 0		RES = 1		RES = 2		RES = 3	
	SENS _{XY}	SENS _Z	SENS _{XY}	SENS _Z	SENS _{XY}	SENS _Z	SENS _{XY}	SENS _Z
0	0.981	1.581	1.963	3.162	3.926	6.324	7.851	12.648
1	0.785	1.265	1.570	2.530	3.141	5.059	6.281	10.119
2	0.589	0.949	1.178	1.897	2.355	3.794	4.711	7.589
3	0.491	0.791	0.981	1.581	1.961	3.162	3.926	6.324
4	0.393	0.632	0.785	1.265	1.570	2.530	3.141	5.059
5	0.327	0.527	0.654	1.054	1.309	2.108	2.617	4.216
6	0.262	0.422	0.523	0.843	1.047	1.686	2.094	3.373
7	0.196	0.316	0.393	0.632	0.785	1.265	1.570	2.530

Table 15: : Sensitivity table for given gain and resolution selection for HALLCONF=0x0

15.1.5. HALLCONF[3:0]

Modifies the hall plate spinning (2-phase vs 4-phase) which has an effect on the minimum sampling rate achievable. Some configurations of OSR and DIG_FILT are not permitted. The cells shown in red are not permitted with HALL_CONF=0xC (default) but are allowed when HALL_CONF=0x0.

Typical T _{CONV} (TXYZ) for OSR ₂ =0x0 [ms]		OSR			
		0	1	2	3
DIG_FILT	0	1.27	1.84	3.00	5.30
	1	1.46	2.23	3.76	6.84
	2	1.84	3.00	5.30	9.91
	3	2.61	4.53	8.37	16.05
	4	4.15	7.60	14.52	28.34
	5	7.22	13.75	26.80	52.92
	6	13.36	26.04	51.38	102.07
	7	25.65	50.61	100.53	200.37

Table 16: T_{CONV} as a function of OSR & DIG_FILT

Maximum ODR for OSR ₂ =0x0 [Hz]		OSR			
		0	1	2	3
DIG_FILT	0	716.9	493.0	303.4	171.5
	1	622.7	408.0	241.5	133.0
	2	493.0	303.4	171.5	91.8
	3	348.0	200.6	108.6	56.6
	4	219.2	119.6	62.6	32.1
	5	125.9	66.1	33.9	17.2
	6	68.0	34.9	17.7	8.9
	7	35.4	18.0	9.0	4.5

Table 17: Maximum Output Data Rate (ODR) as a function of OSR & DIG_FILT

15.1.6. TRIG_INT_SEL

When set to 0 the TRIG_INT pin is in trigger mode. When set to 1 the TRIG_INT pin acts as an interrupt pin.

15.1.7. COMM_MODE[1:0]

When set to 0x2 only SPI communication is allowed. When set to 0x3 only I²C communication is allowed. When set to 0x0 or 0x1 both communication modes can be used but the selection is made by the CS pin.

15.1.8. WOC_DIFF

When wake-on-change mode is enabled this parameter defines the difference needed between the current measurement and the previous measurement ($\Delta\{\text{sample}(t), \text{sample}(t-1)\}$) that will cause the interrupt pin to toggle.

15.1.9. EXT_TRIG

Allows for external trigger events when set to 1 and TRIG_INT_SEL = 0. When enabled an acquisition will start with the external trigger pin detects a high value. Acquisitions will continue to be triggered until the EXT_TRIG pin is brought low.

15.1.10. TCMP_EN

Enables (1) or disables (0) the on-chip sensitivity drift compensation. Enabling the temperature compensation will influence the way the magnetic values are encoded and transmitted to the system microcontroller as shown in the table below.

ABA		TCMP_EN = 0x0		TCMP_EN = 0x1	
		RANGE	TYPE	RANGE	TYPE
RES _i	0	±2 ¹⁵	2's complement 0μT = 0LSB	±2 ¹⁵	unsigned 0μT = 2 ¹⁵ LSB
	1	±2 ¹⁵	2's complement 0μT = 0LSB	±2 ¹⁵	unsigned 0μT = 2 ¹⁵ LSB
	2	±22000	unsigned 0μT = 2 ¹⁵ LSB	N/A	
	3	±11000	unsigned 0μT = 2 ¹⁴ LSB		

Table 18: Output Range and Type as a function of TCMP_EN and RES_XYZ={RES_x,RES_y,RES_z}

15.1.11. BURST_SEL[3:0]

Defines the axes that will be converted in burst mode if the SB command argument is 0.

15.1.12. OSR2[1:0]

Selects the temperature sensor ADC oversampling ratio

15.1.13. RES_XYZ[5:0]

See 15.4.1 GAIN_SEL for the relationship between the gain and resolution. Additionally, section 15.1.10 TCMP_EN for the relationship between RES_XYZ and the output data format.

15.1.14. DIG_FILT[1:0]

See 15.1.5 for the selection of DIG_FILT and the impact on conversion time

15.1.15. OSR[1:0]

Oversampling ratio for the magnetic measurements

15.1.16. SENS_TC_HT[7:0]

Sensitivity drift compensation factor for T > T_{REF}

15.1.17. SENS_TC_LT[7:0]

Sensitivity drift compensation factor for $T < T_{REF}$

15.1.18. OFFSET_i[15:0]

Constant offset correction, independent of temperature, and programmable for each individual axis where $i=X, Y, \text{ or } Z$.

15.1.19. WO_i_THRESHOLDS[15:0]

Wake-on-change threshold. Independently programmable for each magnetic axis ($i=X, Y, Z$) and temperature ($i=T$)

16. Recommended Application Diagram

1.1 I²C

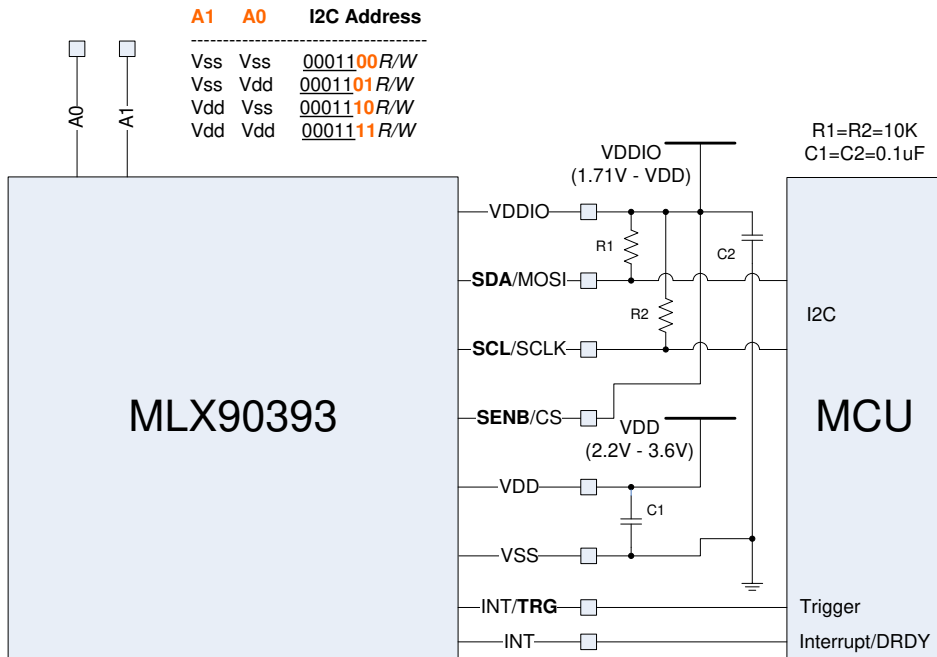

1.2 SPI

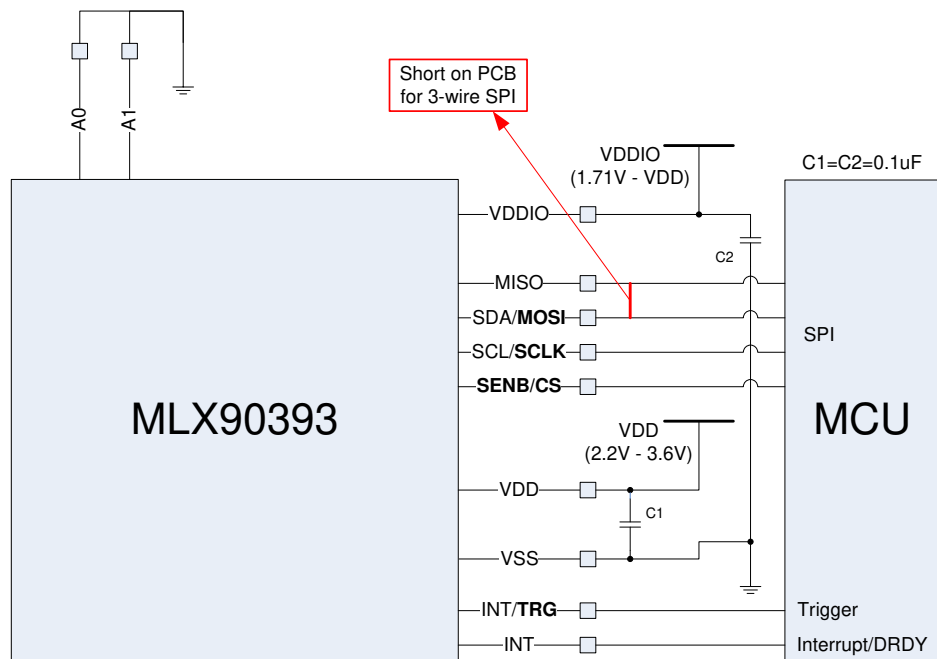

17. Packaging Specification

17.1. QFN package

The MLX90393 shall be delivered in a QFN package as shown below in Figure 9.

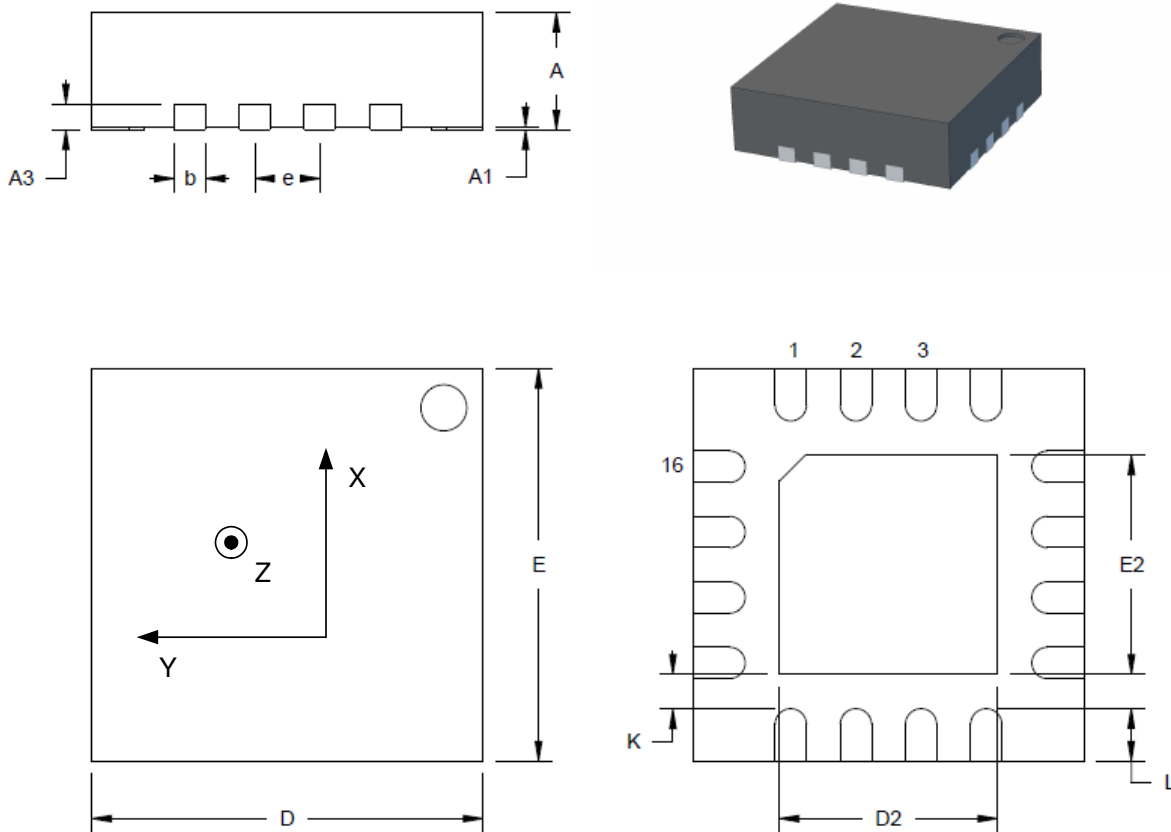

All dimensions in mm

Type	DxE	N	e		A	A1	A3	D2	E2	L	K	b
Quad	3x3	16	0.50	min	0.80	0.00	0.20	1.55	1.55	0.30	0.20	0.18
				max	1.00	0.05	REF	1.80	1.80	0.50	-	0.30

Note:

1. Tolerance of D and E is ± 0.1 mm.
2. Pin 1 bottom identification may vary.

Figure 9: Package Outline Drawing

The sensing elements – Hall plates with the patented IMC technology – are located in the center of the die, which on its turn is located in the center of the package. The pinout (in name and function) is given in section 7.

18. Standard Information

Our products are classified and qualified regarding soldering technology, solderability and moisture sensitivity level according to standards in place in Semiconductor industry.

For further details about test method references and for compliance verification of selected soldering method for product integration, Melexis recommends reviewing on our web site the General Guidelines [soldering recommendation](#). For all soldering technologies deviating from the one mentioned in above document (regarding peak

temperature, temperature gradient, temperature profile, etc.), additional classification and qualification tests have to be agreed upon with Melexis.

For package technology embedding trim and form post-delivery capability, Melexis recommends to consult the dedicated trim & form recommendation application note: [lead trimming and forming recommendations](#)

Melexis is contributing to global environmental conservation by promoting **lead free** solutions. For more information on qualifications of **RoHS** compliant products (RoHS = European directive on the Restriction Of the use of certain Hazardous Substances) please visit the quality page on our website: <http://www.melexis.com/en/quality-environment>

19. ESD Precautions

Electronic semiconductor products are sensitive to Electro Static Discharge (ESD).

Always observe Electro Static Discharge control procedures whenever handling semiconductor products.

20. Revision History

Date	Revision	Remark
11-Nov-2014	001	<ul style="list-style-type: none"> First Document Release
16-Feb-2015	002	<ul style="list-style-type: none"> Changed Ordering Code to indicate QFN wettable flanks Update Document number Added description of yellow cells in Table 1 and Table 2.
13-Jul-2017	003	<ul style="list-style-type: none"> Added additional ordering codes for up to 16 sensors on the same bus and their description in Table 7 Added E temperature code for -40°C capable products and the associated update of the operating range in Chapter 3 Updated template to new Melexis format

21. Contact

For the latest version of this document, go to our website at www.melexis.com.

For additional information, please contact our Direct Sales team and get help for your specific needs:

Europe, Africa	Telephone: +32 13 67 04 95
	Email : sales_europe@melexis.com
Americas	Telephone: +1 603 223 2362
	Email : sales_usa@melexis.com
Asia	Email : sales_asia@melexis.com

22. Disclaimer

The information furnished by Melexis herein ("Information") is believed to be correct and accurate. Melexis disclaims (i) any and all liability in connection with or arising out of the furnishing, performance or use of the technical data or use of the product(s) as described herein ("Product") (ii) any and all liability, including without limitation, special, consequential or incidental damages, and (iii) any and all warranties, express, statutory, implied, or by description, including warranties of fitness for particular purpose, non-infringement and merchantability. No obligation or liability shall arise or flow out of Melexis' rendering of technical or other services.

The Information is provided "as is" and Melexis reserves the right to change the Information at any time and without notice. Therefore, before placing orders and/or prior to designing the Product into a system, users or any third party should obtain the latest version of the relevant information to verify that the information being relied upon is current. Users or any third party must further determine the suitability of the Product for its application, including the level of reliability required and determine whether it is fit for a particular purpose.

The Information is proprietary and/or confidential information of Melexis and the use thereof or anything described by the Information does not grant, explicitly or implicitly, to any party any patent rights, licenses, or any other intellectual property rights.

This document as well as the Product(s) may be subject to export control regulations. Please be aware that export might require a prior authorization from competent authorities.

The Product(s) are intended for use in normal commercial applications. Unless otherwise agreed upon in writing, the Product(s) are not designed, authorized or warranted to be suitable in applications requiring extended temperature range and/or unusual environmental requirements. High reliability applications, such as medical life-support or life-sustaining equipment are specifically not recommended by Melexis.

The Product(s) may not be used for the following applications subject to export control regulations: the development, production, processing, operation, maintenance, storage, recognition or proliferation of 1) chemical, biological or nuclear weapons, or for the development, production, maintenance or storage of missiles for such weapons; 2) civil firearms, including spare parts or ammunition for such arms; 3) defense related products, or other material for military use or for law enforcement; 4) any applications that, alone or in combination with other goods, substances or organisms could cause serious harm to persons or goods and that can be used as a means of violence in an armed conflict or any similar violent situation.

The Products sold by Melexis are subject to the terms and conditions as specified in the Terms of Sale, which can be found at <https://www.melexis.com/en/legal/terms-and-conditions>.

This document supersedes and replaces all prior information regarding the Product(s) and/or previous versions of this document.

Melexis NV © - No part of this document may be reproduced without the prior written consent of Melexis. (2016)

ISO/TS 16949 and ISO14001 Certified