

Arduino Motor Shield

Overview

The Arduino Motor Shield is based on the L298, which is a dual full-bridge driver designed to drive inductive loads such as relays, solenoids, DC and stepping motors. It lets you drive two DC motors with your Arduino board, controlling the speed and direction of each one independently. You can also measure the current absorption of each motor, among other features. The shield is TinkerKit compatible, which means you can quickly create projects by plugging TinkerKit modules to the board.

Summary

Operating Voltage	5V to 12V
Motor controller	L298P, Drives 2 DC motors or 1 stepper motor
Max current	2A per channel or 4A max (with external power supply)
Current sensing	1.65V/A

Free running stop and brake function

Power

The Arduino Motor Shield must be powered only by an external power supply. Because the L298 IC mounted on the shield has two separate power units, one for the logic and one for the motor supply driver. The current draw for the motor supply is often than the USB can give.

External (non-USB) power can come either from an AC-to-DC adapter (wall-wart) or battery. The adapter can be connected by plugging a 2.1mm center-positive plug into the Arduino's board power jack on which the motor shield is mounted or by connecting the wires that lead the power supply to the Vin and GND screw terminals, taking care to respect the polarities.

To avoid possible damage to the Arduino board on which the shield is mounted, we recommend using an external power supply that provides a voltage between 7 and 12V. If your motor require more than 9V we recommend that you separate the power lines of the shield and the Arduino board on which the shield is mounted. This is possible by cutting the "Vin Connect" jumper placed on the back side of the shield. The absolute limit for the Vin at the screw terminals is 18V.

The power pins are as follows:

Vin on the screw terminal block, is the input voltage to the motor connected to the shield. An external power supply connected to this pin also provide power to the Arduino board on which is mounted. By cutting the "Vin Connect" jumper you make this a dedicated power line for the motor.

GND Ground on the screw terminal block.

The shield can supply 2 amperes per channel, for a total of 4 amperes maximum.

Input and Output

This shield have two separate channels, called A and B, that each use 4 of the Arduino pins to drive or sense the motor. In total there are 8 pins in use on this shield. You can use each channel separately to drive two DC motors or combine them to drive one unipolar stepper motor.

The shield's pins, divided by channel are shown in the table below:

Function	pins per Ch. A	pins per Ch. B
Direction	D12	D13
PWM	D3	D11
Brake	D9	D8
Current Sensing	A0	A1

If you don't need the Brake and in the Current Sensing and you also need more pins for your application you can disable this features by cutting the respective jumpers on the back side of the shield.

The additional sockets on the shield are described as follow:

Screw terminal to connect the motors and their power supply.

2 TinkerKit connectors for two Analog Inputs (in white), connected to A2 and A3.

2 TinkerKit connectors for two Aanlog Outputs (in orange in the middle), connected to PWM outputs on pins D5 and D6.

2 TinkerKit connectors for the TWI interface (in white with 4 pins), one for input and the other one for output.

Motors connections

Brushed DC motor. You can drive two Brushed DC motors by connecting the two wires of each one in the (+) and (-) screw terminals for each channel A and B. In this way you can control its direction by setting HIGH or LOW the DIR A and DIR B pins, you can control the speed by varying the PWM A and PWM B duty cycle values. There are also the Brake A and Brake B pins that if setted in HIGH state they brakes the DC motor faster than when you power off the motor. You can know the current going through the DC motor by reading the SNS0 and SNS1 pins. On each channel will be a voltage proportional to the measured current, which can be read as a normal analog input, through the functions `analogRead()` on the analog input A0 and A1. For your convenience it is calibrated to be 3.3V when the channel is delivering its maximum possible current, that is 2A.

Physical Characteristics

The maximum length and width of the Motor Shield PCB are 2.7 and 2.1 inches respectively. Four screw holes allow the board to be attached to a surface or case. Note that the distance between digital pins 7 and 8 is 160 mil (0.16"), not an even multiple of the 100 mil spacing of the other pins.

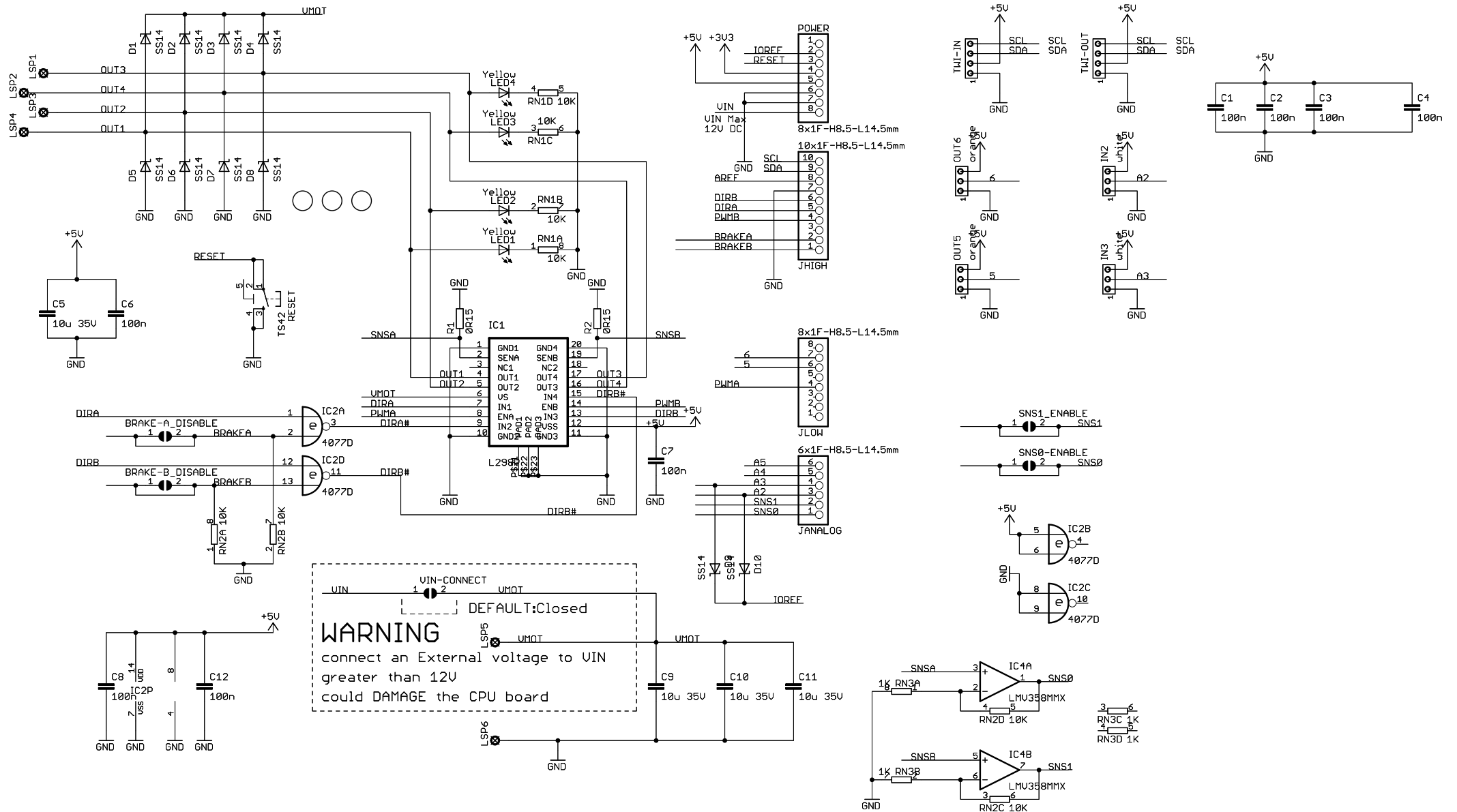

Reference Designs ARE PROVIDED "AS IS" AND "WITH ALL FAULTS. Arduino DISCLAIMS ALL OTHER WARRANTIES, EXPRESS OR IMPLIED, REGARDING PRODUCTS, INCLUDING BUT NOT LIMITED TO, ANY IMPLIED WARRANTIES OF MERCHANTABILITY OR FITNESS FOR A PARTICULAR PURPOSE. Arduino may make changes to specifications and product descriptions at any time, without notice. The Customer must not rely on the absence or characteristics of any features or instructions marked "reserved" or "undefined." Arduino reserves these for future definition and shall have no responsibility whatsoever for conflicts or incompatibilities arising from future changes to them. The product information on the Web Site or Materials is subject to change without notice. Do not finalize a design with this information. ARDUINO is a registered trademark.