

Nano Footprint  
VCC: 3.3V (Qwiic)

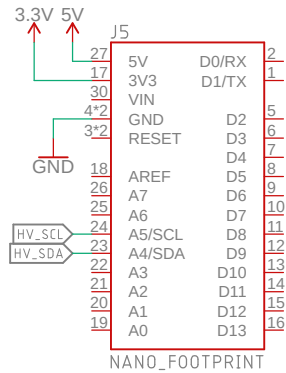

IO Voltage Selection

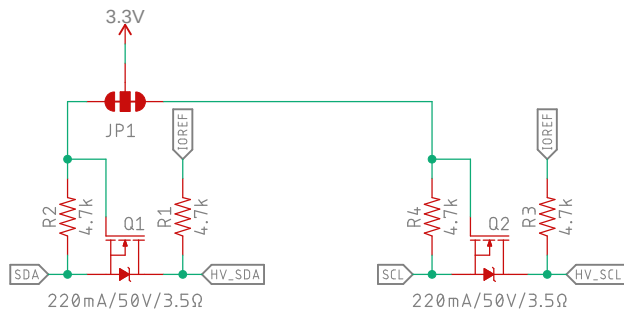
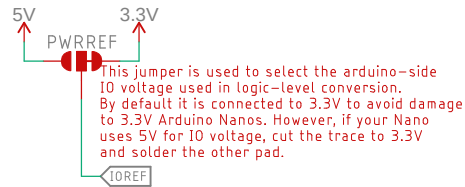

Qwiic Connections

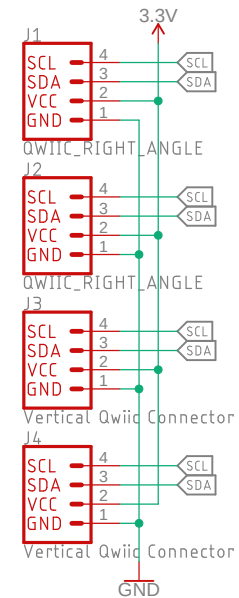

Released under the Creative Commons Attribution Share-Alike 4.0 License  
<https://creativecommons.org/licenses/by-sa/4.0/>

TITLE: Qwiic\_Shield\_for\_Arduino\_Nano

Design by: Andy England

REV: v10

Date: 1/30/2020 9:13 AM

Sheet: 1/1